

Summary

| | |
|--|----------|
| PRODUCT CHARACTERISTICS | |
| 1. SARAY® applications | p. 4 |
| 2. SARAY® description | p. 4-5 |
| RECOMMENDATIONS BEFORE USE | |
| 1. Storage, handling of panels and shipping of fabricated elements | p. 5 |
| 2. Protective equipment | p. 5 |
| 3. Precautions relating to the product | p. 5 |
| TOOLS | |
| 1. Machines | p. 7 |
| 2. Accessories | p. 9 |
| 3. Tools | p. 9 |
| MACHINING | |
| 1. Preparation for machining - calculation of design dimensions | p. 10-12 |
| 2. Sawing | p. 12 |
| 3. Milling | p. 13-15 |
| 4. Corner cutting, notches, pre-drilled holes | p. 16 |
| FABRICATION | |
| 1. Folding | p. 17 |
| 2. Bending | p. 18 |
| ASSEMBLY | |
| 1. Riveting | p. 20 |
| 2. Screw fastening | p. 21 |
| 3. Continuous edge grip | p. 21 |
| 4. Gluing | p. 22-23 |
| 5. Hot air welding | p. 24-25 |
| 6. Panel reinforcement | p. 25 |
| SURFACE TREATMENT | |
| 1. Post painting | p. 26 |
| 2. Screen printing | p. 26 |
| 3. Application of adhesives | p. 27 |
| MAINTENANCE | |
| 1. Cleaning | p. 29 |
| 2. Coating touch-ups | p. 29 |
| INFORMATION AND SERVICE | |
| 1. Projects | p. 30 |
| 2. Processing | p. 30 |
| 3. Installation | p. 30 |
| 4. Other information | p. 30 |
| Warning | p. 30 |
| GLOSSARY | p. 31-32 |
| NOTES | |

1. SARAY® applications SARAY® offers a flexible, durable solution in many areas of activity. It combines ease of use with exceptional strength and a high quality coil coated finish.

a) Architectural uses

SARAY® is suitable for outdoor and indoor architectural applications in new buildings or refurbishment work. Ideal for exterior cladding, SARAY® adapts to your shapes and colour requirements. For ventilated facades, SARAY® panels can be used as flat, bent or fabricated into cassettes.

A technical back-up team is available to assist users in optimising dimensions and in the choice of fastening systems, profiles or other accessories useful for installation.

b) SARAY® for Corporate Identity Design (CID) and Sign & Display applications

SARAY® enables companies and organizations to display their corporate identity, using a reliable process with multiple possibilities.

ALUBOARD® is suited for display applications such as signage, advertising panels, shop fittings, exhibition stands and light boxes.

ALUBOARD® finish is ideal for screen printing*, post-painting and the application of adhesives.

FABRICATION OF SARAY®

Product characteristics

c) SARAY® for industry and transport SARAY® and ALUBOARD® also provide innovatory solutions for industrial and transport engineers.

They can be used for rollers, cases, containers, machine protection and enclosures, but especially for cladding on public transport vehicles, trailers, trucks etc.

2. SARAY® description

SARAY® is a composite panel consisting of two pre-coated aluminium sheets bonded onto both side of a polyethylene core. Bonding of the aluminium and core is achieved by both chemical and mechanical action, which gives SARAY® remarkable bond integrity. An exceptionally flat, corrosion-resistant panel, SARAY® is easy to use. SARAY® panels are simple to fabricate* and can be used to make many different forms with minimum investment.

a) SARAY®

- Two 0.5 mm thick pre-coated aluminium sheets.

- 3, 4 and 6 mm standard nominal panel thickness.

- weight and density of the panels (density):

3 mm - 4.59 kg/m²

4 mm - 5.51 kg/m²

4 mm (FR) - 7,5 kg/m²

6 mm - 7.36 kg/m²

- Upper sheet finish:

PVDF* 70/30

These panels are particularly UV and weather resistant and come in several standard colours. The range can be extended to any other colours (RAL, NCS, etc.) subject to a minimum production quantity.

- Lower sheet finish: protective primer.

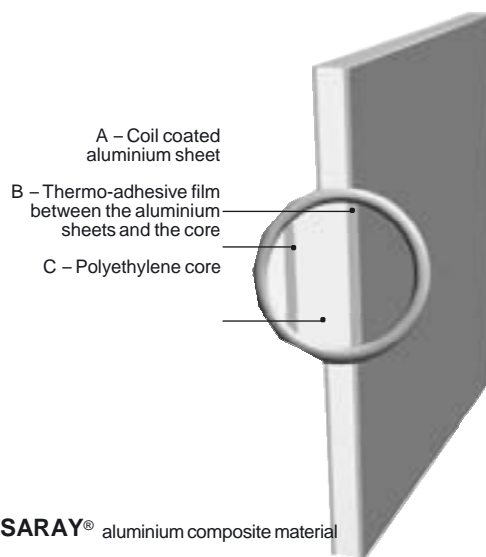

SARAY® aluminium composite material

b) **ALUBOARD®**

- Two 0.3 mm thick pre-coated aluminium sheets.
- 2, 3 and 4 mm nominal standard panel thickness.
- panel weight (density) :
 - 2 mm - 2.90 kg/m²
 - 3 mm - 3.80 kg/m²
 - 4 mm - 4.75 kg/m²

Upper and lower sheet finishes can be polyester or in PVDF.

Available in standard colours with 25 % to 80 % gloss rating. This range can be extended to any other colours (RAL, NCS, etc.) subject to a minimum production quantity.

c) Paint Finishes : PVDF* 70/30, or Polyester

The **SARAY®** panel is available in PVDF* 70/30 coating, or polyester. Custom colour formulations in opaque, metallic or mica finishes offer virtually the full range of colours required for architectural uses.

FABRICATION OF SARAY®

Product characteristics

- PVDF* 70/30 coatings offer excellent resistance against aging and are at the present time the most sophisticated in the building sector.
- There are coatings particularly suitable for metallic colours.
- Polyester coatings offer a high UV and weather resistance and are suitable for screen-printing, the application of adhesives and post-painting using the liquid spray technique.

Diagram of the coil-coating line

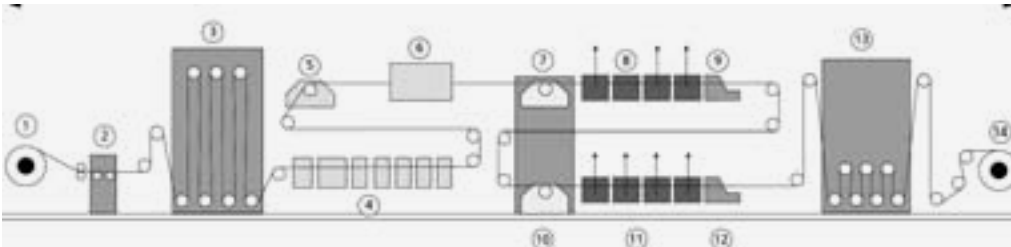

- | | |
|---------------------------|-------------------------|
| ① Uncoiler | ⑧ Primer oven |
| ② Stitcher | ⑨ Air and water coolers |
| ③ Entrance accumulators | ⑩ Finish coater |
| ④ Degreasing | ⑪ Finish oven |
| ⑤ Anticorrosion treatment | ⑫ Air and water coolers |
| ⑥ Dry in place oven | ⑬ Exit accumulators |
| ⑦ Primer coater | ⑭ Recoiler |

The aluminium sheets used to manufacture **SARAY®** composite panels are treated against corrosion and coil-coated at our Velikoy (Cerkezkoj) plant. Coil-coating is a continuous paint application process that provides a coating uniformity that is exceptional, both qualitatively and aesthetically.

*cf. glossary

d) Production tolerances

SARAY® panels are produced to the following tolerances:

| | |
|--|-------------------|
| Thickness 3 and 4 mm : | ± 0.1 mm |
| Width : | - 0/+3 mm |
| Length ≤ 4000 : | - 0/+3 mm |
| Length > 4000 and < 6000 mm : | - 0/+4 mm |
| Length ≥ 6000 mm : | please consult us |
| Maximum difference between diagonals : | 3 mm |
| Difference on superposition : | ±1.5 mm |

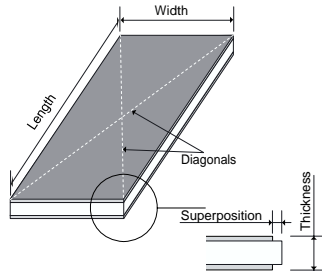

e) Protective film

The film protects the paint finish during fabrication and installation. It should, however, be removed as soon as possible after installation of the panel on site, especially in the case of panels exposed to sunlight and weather. The protective film should only remain temporarily on the panels. Arrows are printed on the film to indicate the direction of coil-coating (important for metallic finishes).

Types of film :

- Opaque film 80 μ thick with ultraviolet barrier is used on **SARAY®**
- Transparent film 35 μ thick is applied to **ALUBOARD®** for Sign & Display applications.

Protective film

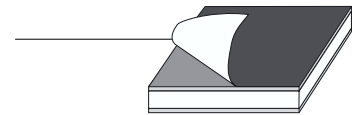

FABRICATION OF SARAY®

Product characteristics

e) Packaging

ALUBOARD®

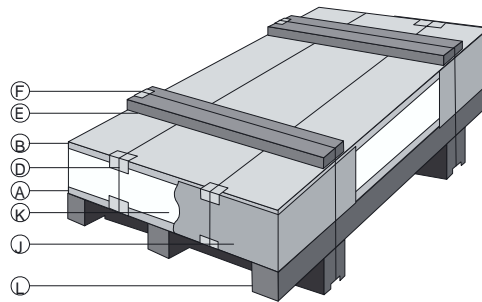

- (A) Cardboard placed on the pallet
- (B) Cardboard placed on the last panel
- (C) Agglomerated woodchip cover
- (D) Longitudinal banding + 4 cardboard corners per band
- (E) Stacking planks
- (F) Transverse banding + 4 cardboard corners per band

SARAY®

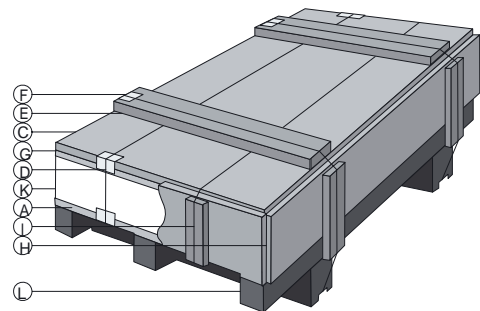

- (G) Polyethylene film (packages of over 20 panels)
- (H) Agglomerated woodchip sides (packages of over 20 panels)
- (I) Wooden blocks (packages of more than 20 panels)
- (J) Cardboard sides (packages of more than 20 panels)
- (K) **SARAY®**
- (L) Pallet

1. Storage, handling of panels and shipping of fabricated elements

a) Panels must be stored in a cool, dry area

We recommend to store the panels in the workshop at approximately 18 °C for at least 24 hours before processing operations begin.

b) The handling of SARAY®

Panels requires a certain amount of care and it is therefore recommended that they be supported at several points along their length (the number of support points depending on the length of the panel).

When storing panels temporarily between different phases of fabrication, use polystyrene or foam-wedges.

c) Essential precautions

Fabricated elements will be packaged in identical fashion in closed crates with blocks between the elements. The latter will be placed so as to avoid the elements coming into contact with each other and moving inside the crate.

2. Protective equipment

Individual protective equipment should be worn in accordance with the safety regulations in force in the workshops. However, we also recommend that you wear:

- gloves : for handling the panels at all stages.
- goggles : for the fabrication operations that produce swarf (sawing, milling*, drilling*...).
- ear protection : when using very noisy machinery (panel saw...).

FABRICATION OF SARAY®

Recommendations before use

3. Precautions relating to the product

a) Thermal expansion

SARAY®

panels may only be used at temperatures between - 50 °C and + 80 °C and will thermally expand or contract in exactly the same way as solid aluminium plate or sheet.

This thermal expansion must be born in mind when choosing the fastening system and calculating dimensions and joint widths. SARAY®

has a coefficient of expansion of $2.36 \times 10^{-5} \text{ m/}^\circ\text{C}$ (0.0236 mm/m/°C).

Example :

For a panel exposed to weather conditions with temperatures varying between - 20 °C in winter and + 40 °C in summer, we have a temperature difference of 60 °C.

Remarks :

- bear in mind the ambient temperature during fabrication*.
- panels with outer coatings in darker colours absorb more heat than lighter colours. Account must be taken of this when calculating the temperature difference (about 20 °C more for a black panel compared to a white or metallic panel).
- expansion is not the only tolerance factor to be taken into consideration during design calculations: account must also be taken of the tolerances of the support (masonry, structural steel) and the installation tolerances (joinery, wall openings, etc.).

| Length of panel | 2 m | 3 m | 4 m | 6 m |
|---|---------|---------|---------|---------|
| Expansion for a temperature difference of 60 °C | 2,84 mm | 4,26 mm | 5,68 mm | 8,52 mm |

*cf. glossary

b) Direction of coil coating

Metallic and mica coatings have a reflective or pearlescent finish, due to the millions of microscopic aluminium or mica particles suspended in the paint mix.

These particles are oriented in the longitudinal direction during the coil coating process.

During production, arrows and a production number are printed on the back surface of the panels.

Directional arrows are also printed on the strippable protective film.

Consequently, it is important when fabricating and installing panels with metallic or mica coatings to take this orientation into account. Panel directionality must be maintained in order to avoid shading differences between adjacent panels and must be taken into account when making the optimisation calculations.

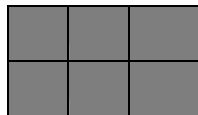

yes

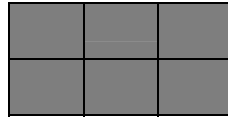

yes

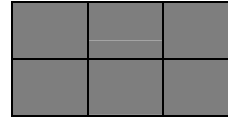

no

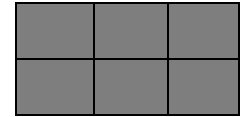

no

FABRICATION OF SARAY®

Recommendations before fabrication

Recommendations:

Before fabrication*, remember to use a felt tip pen to draw arrows to indicate the coating direction on any small pieces that might be cut out from areas without the directional arrows.

Coating orientation is, however, not the only factor of difference in colours. All metallic and mica coatings are in fact subject to variations in appearance between batches.

In this case, Alcoa strongly advises not mixing panels from different batches on the same wall elevation in order to avoid shading differences.

c) Contact with other materials

Only plastics, stainless steel, aluminium and zinc may be directly assembled with **SARAY®** without taking any special precautions (as long as stainless steel or aluminium screw fasteners are used).

In all other cases, it will be necessary to protect the contact surface using a non-porous coating such as cadmium, zinc, aluminium, chrome or organic varnishes. Direct contact between the aluminium sheet covering the **SARAY®** and heavy metals (e.g. copper, brass, bronze, iron) creates a high risk of corrosion. If such materials must be used for contact parts, they must be coated or separated from the **SARAY®** by electrically insulating inserts

(e.g. plastic mounting plates or washers...).

*cf. glossary

1. Machines

The tools necessary for processing **SARAY®** may be chosen according to the criteria and conditions detailed in the table below :

| | Large scale cutting | Small scale cutting | Occasional cutting | Milling * | Drilling* | Punching* | Riveting* | Boring* | Tapping |
|----------------------------|---------------------|---------------------|--------------------|-----------|-----------|-----------|-----------|---------|---------|
| Ⓐ Vertical panel saw | • | • | | • | | | | | |
| Ⓑ Circular saw | | • | | | | | | | |
| Ⓒ Jigsaw | | | • | | | | | | |
| Ⓓ Shearing machine | • | • | | | | | | | |
| Ⓔ Milling machine | | | | • | | • | | | |
| Ⓕ Routing machine | | | | • | | | | | |
| Ⓖ CNC flat milling machine | • | • | | • | • | • | | • | • |
| Ⓗ Punching machine | | | | | | • | | | |
| Ⓘ Drilling machine | | | | | • | | | • | • |
| ⓵ Rivet gun | | | | | | | • | | |

FABRICATION OF SARAY®

Tools

Ⓐ Vertical panel saw

The best saw which is suitable for large runs of work and for better cutting accuracy. Certain models may be fitted with a milling* device.

Ⓑ Circular saw

Particularly appropriate for use in a workshop or on site. Simple to use, it cuts panels at high speed.

The use of a flat trapezoid toothed blade and a negative cutting angle gives good results when cutting aluminium.

- The blade may be either high speed steel (HSS) or carbide tipped steel (MC).
- The feed speed will be of about 20-25 m/min depending on the type of high-speed steel or carbide blade.

Ⓒ Jigsaw

Allows the cutting of complex shapes or small cut-outs. It is not suited to sawing long straight lines.

The maximum feed speed can be up to 6 m/min and must be adapted to the surface finish required. When starting a run, it is advised that you make some prototypes to check the quality of the finish. In this way, one or more parameters can be varied to obtain a better result.

In all cases, it is desirable to eliminate any source of vibration caused by the saw or by poor fastening of the part.

Ⓓ Shearing machine

SARAY® may be cut with a shearing machine, whether circular or guillotine shears.

If using guillotine shears, we recommend that flexible protective inserts be placed between the holding block and the panel to avoid a mark being left on the aluminium skin when the guillotine comes down.

Remark : a slight turned down top skin may be left along the leading edge of the sheared panel.

*cf. glossary

Ⓔ Milling machine

All the conventional milling machines (universal, vertical or horizontal) are commonly used on **SARAY®**. However, we recommend the use of protection on the locking device to avoid it leaving marks where it was tightened on the panels.

The wide-spaced teeth, the rounded, smooth grooves and the small cutting angle of the high-speed steel or carbide-tipped milling cutters makes this a suitable tool for machining **SARAY®**.

Ⓕ Routing machine

Hand-held machines allow groove cuts* to be made on large surface panels or milling along the edge (folded edge, edge insert).

The use of a guide rail or template allows better accuracy and good repeatability of the operation.

Ⓖ CNC flat milling machine

All the **SARAY®** machining operations can be performed on a single machine: the numerically controlled flat milling machine.

Cutting, machining and drilling* operations etc. can be performed very rapidly with a high degree of accuracy thanks to a multiple tool holder head and of the reduction of handling of the panel between operations.

The CNC milling machine is the most rational tool for machining **SARAY®** in large runs or where a high degree of accuracy is required.

FABRICATION OF SARAY®

Tools

Specific arc-shaped or elliptical cuts will be extremely accurate and the finish will be perfect. Any shape, any type of notch or indentation is possible.

Ⓗ Punching machine

The technique of cutting **SARAY®** by punching is the same as that used for aluminium sheet. It offers remarkably clean cuts thanks to the high characteristics of the alloy used and the lubricating function of the polyethylene core. The working clearance between the die and the punch should be ± 0.15 mm.

The cleanness of the cut depends on the geometry of the tool and the punch speed. We recommend that you do a few experimental runs in order to find the optimum setting.

Ⓘ Drilling machine

SARAY® may be drilled with the same machines and the same twist drill bits as those used for drilling* steel or aluminium sheets.

We recommend that the bit be removed regularly from the hole and a blow gun* be used to remove swarf. If the quality of the finish is poor after drilling, we recommend that you reduce the cutting speed or feed speed. A few test runs will allow you to check the quality of the finish.

Tapping of aluminium accessories

:

We recommend the use of special taps for aluminium. Often the use of the finishing tap is enough. These taps have wide, rounded, polished flutes presenting a wide cutting angle. Progressive or spiral fluted taps offer the best swarf evacuation, as do those whose threads are cut by staggered flutes.

When tapping using a fixed machine, the taps used will be those used for machining aluminium in one pass.

*cf. glossary

Boring*:

To bore **SARAY**® a counterbore or a three-groove inserted shank reamer may be used. The holes worked with the reamer will be less out of round than those drilled with a two-lip drill bit. To countersink cone screw heads, an angular milling cutter or counterbore will be used.

Ⓜ Rivet gun

The rivet gun is an essential tool for making cassettes: it is used to assemble the cassette after fabrication*.

All types of rivet gun are suitable, pneumatic or electric, even mechanical for small runs.

The rivet gun is also an essential tool on site, for installing panels in a riveted system, or for fixing frame profiles.

2. Accessories

a) *Wood chisel*

The wood chisel can be used for occasional jobs such as reworking an edge or cutting out corners for short fabrication runs.

b) *Metal file*

A file can be used to trim the sharp edges left by machining operations.

It can also be used to adjust dimensions, when cutting with a wood chisel, for example.

c) *Blow gun**

A blow gun* is a very practical accessory for removing swarf and filings from work surfaces and the panels machined. This tool does require the installation of a compressed air system.

FABRICATION OF SARAY®

Tools

3. Tools

The cutting tools (milling cutters, drill bits, disks, blades) suitable for the machining of **SARAY**® panels are those used for traditional machining of aluminium, of the high-speed steel or carbide type.

They will be chosen according to the type of machine-tool used:

| | Circular tool Ø 300 Cutting | Circular tool Ø 242 V-shaped milling cutter 90° | Circular tool Ø 242 V-shaped milling cutter 90° | Circular tool Ø 242 U-shaped milling cutter 135° | Circular tool Ø 242 U-shaped milling cutter | Circular tool Ø 160 Cutting | Cylindrical tool - Ø 23 V-shaped milling cutter 90° | Cylindrical tool - Ø 38 V-shaped milling cutter 90° | Cylindrical tool - Ø 14 U- shaped milling cutter 135° | Special blade for aluminium |
|--------------------------|--------------------------------|--|--|---|--|--------------------------------|--|--|--|-----------------------------|
| Vertical panel saw | • | • | • | • | | | | | | |
| Circular saw | | | | | • | | | | | |
| Jigsaw | | | | | | | | | | • |
| Milling machine | | | | | | • | • | • | | |
| Routing machine | | | | | | • | • | • | | |
| CNC flat milling machine | • ⁽¹⁾ | • ⁽¹⁾ | • ⁽¹⁾ | • ⁽¹⁾ | | • | • | • | | |

⁽¹⁾ depending on CNC model

*cf. glossary

General fabrication* techniques

SARAY® composite panels can be fabricated using extremely simple techniques and machinery.

Standard or complex elements can be made with minimum investment. However, the specific characteristics of the composite material require certain precautions : **read carefully chapter “Recommendations before use”, paragraph “Handling of panels” page 7.**

After fabrication, SARAY® panels are easily shaped.

This stage of the process can be performed after delivery to the site, which has the advantage of considerably reducing transport costs.

Here we will present some fabrication techniques with our recommendations.

It is, however, essential that you ensure that you have all the technical information concerning the machines used and that you follow the manufacturer's operating instructions. The aim being to carry out the fabrication operations on a finished material without damaging it (scratches, knocks, twisting, etc.) This so that the user receives finished, shaped elements of irreproachable quality.

FABRICATION OF SARAY®

Machining

1. Preparation for machining - calculation of design dimensions

Closed 90° fold - milling cutter with 3 mm flat surface:

When milling for a fold, a thickness of 0.3 mm of polyethylene should be left in the bottom of the groove, on top of the thickness of the aluminium

(see procedure in the Milling chapter*).

For a fold milled with a cutter with a flat surface of 3 mm, the fold axis will be in the middle of the milled groove flat, therefore 0.8 mm from the visible face. This, in the case of a closed 90° fold leads to an oversize of 0.8 mm per angle. In practise, we round this off to 1 mm for ease of calculation.

When making a closed fold with a milling cutter with a 3 mm flat surface, the exterior finished dimension is increased by about 1 mm.

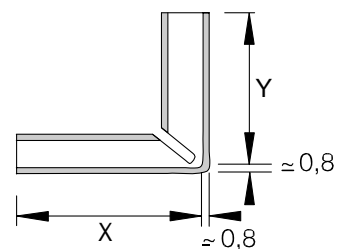
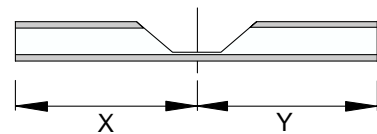

Fold and counterfold:

In the case of a fold and a counterfold in the other direction, the problem is different (always work on the reverse side of the panel, whether the fold is open or closed).

In the case of an open fold, the fold axis is still in the middle of the milled groove, but the fold is not formed around that axis, but outwards, which causes the polyethylene to stretch.

When an open fold is added to a closed fold, by the fold - counterfold upwards technique, the following occurs: When an outward fold is made with a groove cutter with a 3 mm flat surface, the finished exterior dimension is reduced by 1 mm.

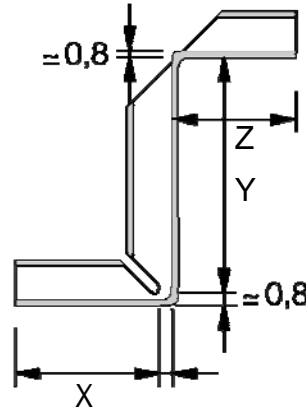
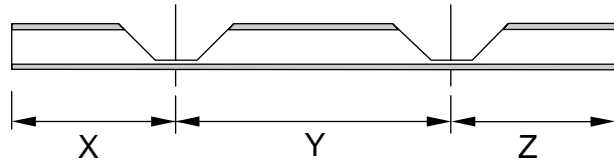

FABRICATION OF SARAY®

Machining

Example:

Making two side folds on a cassette – with a milling cutter with a 3 mm flat surface.

Conclusion:

The flat size of panels to be cut and milled must be calculated and marked out before any machining work is begun.

This will allow fabrication within the best possible tolerances.

The tolerances generally accepted on fabricated elements are ± 1 mm, when using a milling cutter with a 3 mm flat surface.

In all cases, a test run should be performed beforehand, to work out the adjustments to be made to the dimensions.

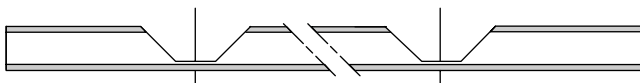

2. Sawing

a) Measurements to be taken

Before any cutting is undertaken, it is necessary to calculate the flat size of the elements taking into account the folding parameters and the dimensional characteristics indicated in the paragraph above "Preparation for machining", page 12.

Cutting panels :

Before starting a long run, we recommend that as a precaution, you check with the blade and with a rule.

For the trimming of the panels, generally speaking, the width of the blade is sufficient. Remember that it is useful to check with a rule and to calibrate measuring instruments regularly.

b) Sawing methods and tools

Although it is possible to cut **SARAY**[®] panels with a jigsaw, we would only recommend its use for occasional work or specific cuts.

Circular saw :

SARAY[®] panels are cut in the same way as solid aluminium plate.

Three basic precautions need to be taken :

The work area must be kept clean, an exhaust system must be used and you would work on the reverse of the panel. This will reduce the risk of scratching to a minimum. Moreover, when working on a bench, wherever possible, the panel being fabricated should be placed on polystyrene blocks and care should be taken to ensure they do not get incrustated with swarf.

FABRICATION OF SARAY[®]

Machining

We recommend the use of guides whose length exceeds that of the panel to be cut by 200 mm at each end. It is possible to cut several panels at the same time. However, to guarantee the longevity of the equipment, we do not recommend superposing more than two 4 mm **SARAY**[®] panels.

Panel saw :

As for cutting with a circular saw, you must work on the reverse of the panels (the side with the strippable protective film against the saw frame). The stops will be placed to the left of the sawing column so that the operator can hold the sawn pieces. Trimming is quicker and easier than with a circular saw.

Now we detail this operation.

The first cut is made horizontally, at the upper edge*, to get a straight edge. Then turn the panel so that the reference edge* is resting on the carrying rollers. Make a vertical cut on the left edge* of the panel. You now have a panel with straight edges, a straight base and right angles. The panel is now ready to be cut into the different pieces.

In some cases it may be possible to cut 4 to 5 panels or more at the same time. Test runs should be performed before starting production.

1) cut on the upper edge*

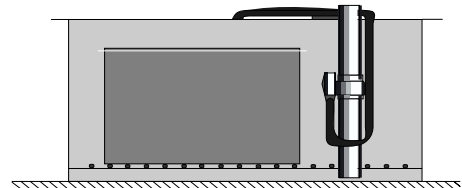

2) turn the panel round



3) vertical cut

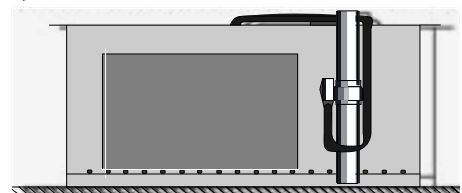

4) the panel is ready to be cut into pieces A, B, C...

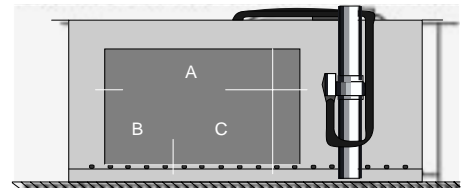

Given the **SARAY**[®] generally has few burrs. If a rough cut is made, it may be trimmed with the tools conventionally used

*cf. glossary

3. Milling*

a) Measurements to be taken

Before any milling operations, it is necessary to calculate the flat size of the elements taking into account the folding parameters and the dimensional characteristics indicated in the paragraph above "Preparation for machining", page 12.

b) Milling* methods

The method used for milling* operations will depend on the tools available and the job to be done:

| | | Long runs | Short runs | Occasional cuts | Method |
|---|--------------------------|-----------|------------|-----------------|--------|
| A | Vertical panel saw | • | • | | 2 |
| B | Circular saw | | • | • | 2 |
| E | Milling machine | • | | | 1 |
| F | Routing machine | | • | • | 1 |
| G | CNC flat milling machine | • | • | | 1 |

FABRICATION OF SARAY®

Machining

Method 1) Routing machine, milling machine and CNC flat milling machine

We would remind you that you must always keep the front side intact as well as a minimum thickness of polyethylene in the bottom of the milling groove (polyethylene thickness is of

0.3 mm for V-shaped groove, and 1 mm for a concave milled groove).

To achieve this, you must define a point 0. We begin by placing the milling cutter in contact with the surface to be milled, and using wedges or the depth adjustment wheel, we subtract the value of the milling cut. Before beginning work on the panel, it is prudent to check the adjustment of the router by making a short milling cut. Do not hesitate to modify the milling depth if necessary. In the case of a V-shaped rout, the optimum thickness of the polyethylene is 0.3 mm. If there is more than 0.5 mm the fold will not close properly, and if there is less than 0.1 mm, there is a risk of breaking the return on folding.

The table opposite gives some examples of values:

Cylindrical tools :

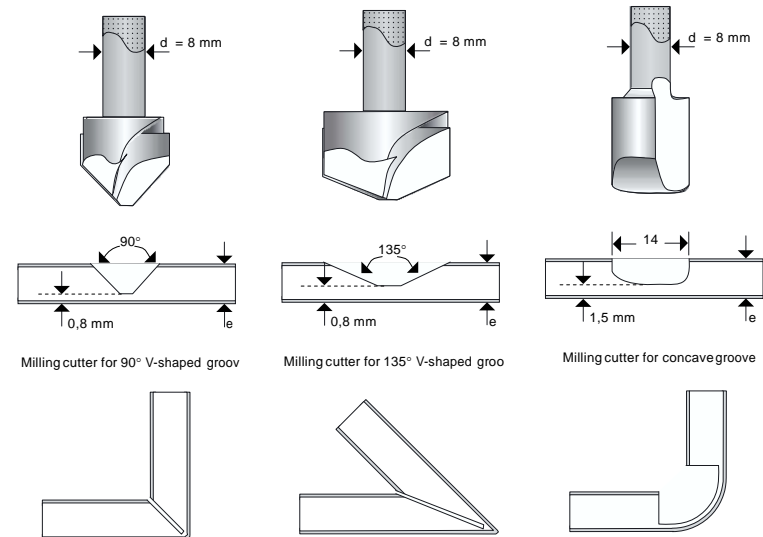

| | | V-shaped groove | | | Concave* groove | | | V-shaped groove | | | Concave* groove | | |
|---|------------------------|-----------------|----|----|-----------------|----|----|-----------------|----|----|-----------------|----|----|
| | | SARAY® | | | | | | ALUBOARD® | | | | | |
| | | 3 | 4 | 6 | 3 | 4 | 6 | 2 | 3 | 4 | 2 | 3 | 4 |
| A | thickness | | | | | | | | | | | | |
| B | thickness | 01 | | | 01 | | | 0,3 | | | 0,3 | | |
| C | Residual PE* | 0 | | | 001 | | | 0 | | | 001 | | |
| D | Value to be subtracted | 02 | 03 | 05 | 02 | 03 | 05 | 01 | 02 | 03 | 01 | 02 | 03 |

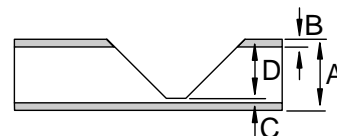

*cf. glossary

Method 2) Panel saw:

No specific settings are necessary : the milling depth is defined by the tracer disk. On the other hand, it is essential that an extra panel 30 mm thick be placed on the base plane. This panel must be wider and longer than the composite panel to be milled. The surface condition and the flatness of this extra panel must be perfect. The quality of the fabrication work depends on it.

We recommend the use of a gaboan latted board 20 mm thick with a 10 mm thick plywood panel screwed onto it. It is on this plywood surface that all the work will be done. This can be replaced at little cost if it is inadvertently damaged

For the milling of large **SARAY®** panels, we recommend that you make a large panel with support studs. These can be made of off-cuts of **SARAY®**. They will be screwed onto the panels, which means they can be changed as they become worn.

Warning : do not use the stops intended for sawing when milling. The milling axis is offset in relation to the left edge of a saw blade cutting edge. As the machine is supplied with several stops, some of them must be calibrated for sawing operations and others for milling operations.

FABRICATION OF SARAY®

Machining

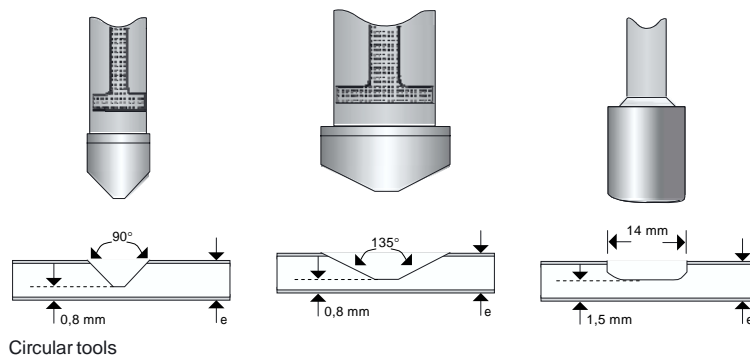

Circular tools

It is a good idea to mark the point of impact of the cutter on the suction hood of the saw. This allows a more accurate approach and limits milling "overflow".

When milling very close to the edge, ensure that the tracer disk is in contact with the panel.

An off-cut of the same thickness could be added.

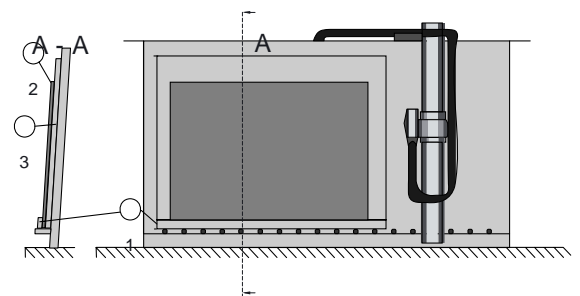

A

- ① 50 mm wide SARAY® panel.
- ② 10 mm thick plywood panel.
- ③ 20 mm thick gaboan latted board.

*cf. glossary

c) Rout and return

The rout and return technique consists of using shaped milling cutters to make V-shaped or straight grooves on the back of the **SARAY®** composite panel.

This allows, in most cases, the hand folding of the panels on site without any need for a folding bench. A folding rule consisting of a U or H-shaped profile with a lever can be used to make hand folding easier. See paragraph "Folding", page 19.

The grooves can be made using a routing machine, a fixed panel saw or a horizontal milling table.

Routing :

Bending radii of between 2 and 10 mm inclusive can be obtained depending on the choice of milling technique and the geometry of the groove.

- V-shaped groove :

This allows a bending radius of at least 2 mm.

The angle of the groove may be 90° or 135°.

Important: to ensure that enough of the polyethylene core is removed in the case of a 90° fold, you are advised to opt for a groove flat of 3 mm.

FABRICATION OF SARAY®

Machining

- Other types of groove :

A straight groove with a concave bottom allows folding radii of between 7 mm and 10 mm, depending on the depth of the groove. Try some experimental bends to check the bend.

The use of a step cutter will allow the removal of the polyethylene core for plastic welding applications.

Whatever the shape of the groove, the front sheet must remain intact and we recommend that you retain a minimum thickness of polyethylene at the bottom of the groove.

This residual thickness of polyethylene is 0.3 mm for a V-shaped groove. It will be between 0.5 mm and 1 mm inclusive for a straight groove with concave bottom.

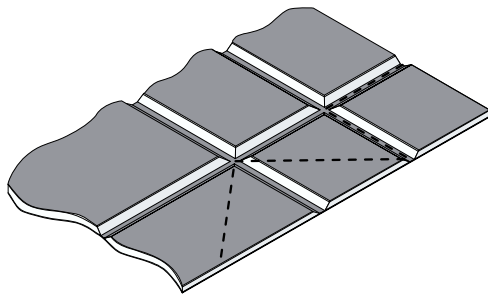

4. Corner cutting, notches, pre-drilled holes

Two methods are commonly used for cutting out corners to allow the forming of a cassette.

a) *Punching**

This technique is the most productive, with the corners being cut out and the corner fastening holes being put in a single operation. We have developed a punch that can be used on our KS, KU and KH systems.

This tool is also suited to drilling* and notching (also possible with a CNC machine).

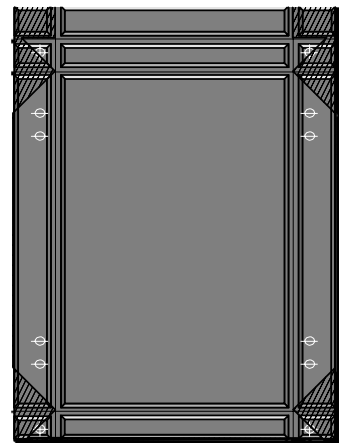

FABRICATION OF SARAY®

Machining

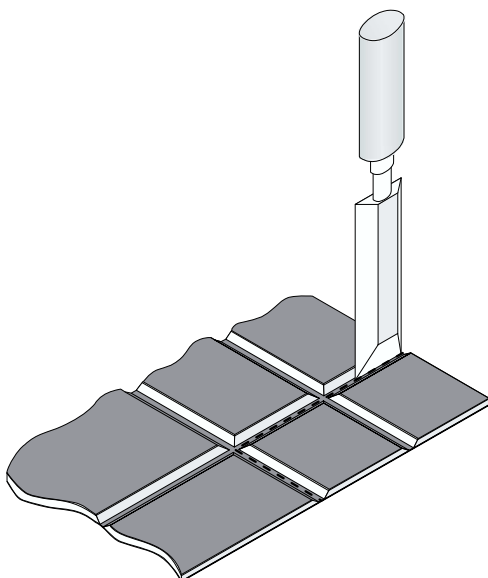

b) *Wood chisel*

A sharp hammer blow to a wood chisel allows you to cut out the small thickness at the bottom of a routing groove with no difficulty. The wood chisel must be wider than the part to be cut out.

With a little experience, good clean joints can quickly be made.

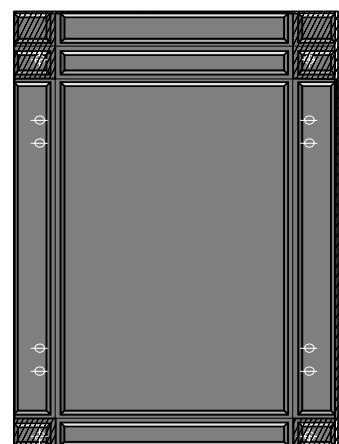

1. Folding

a) General recommendations

Generally speaking, it is essential to :

- fold the return leg back in one movement,
- close the fold 10 to 20° more than the desired angle before making the exact angle.

This avoids a slight spring back effect.

Folding is done by hand using a tool you can make yourself.

Depending on the folds, the following techniques may be used :

b) Folding methods

Folding with a U or H jig:

U or H-shaped, it is fitted with a handle to facilitate the operation. This jig is particularly suited to folding small pieces.

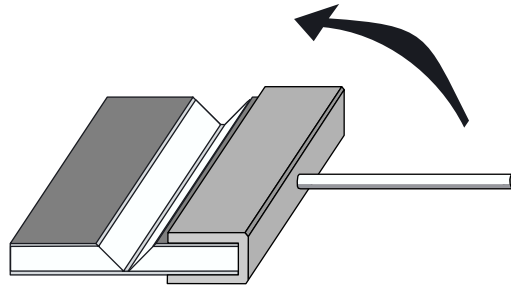

FABRICATION OF SARAY®

Fabrication

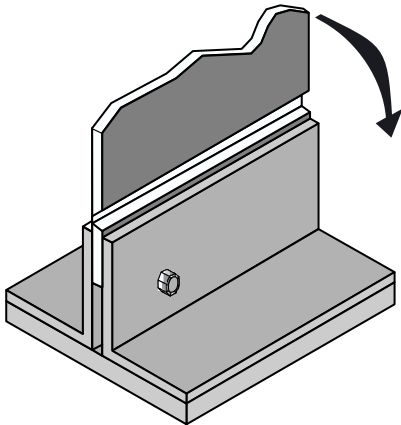

Folding with a folding bed :

This is a jig fixed onto a base. The panel is placed vertically in the jig. As the panel will tilt under its own weight, not much effort is required.

This technique is particularly suited to the folding of returns, especially for long lengths or small folding widths.

Other folds :

Folds, counterfolds, abutted edges require a knack that is acquired with experience.

Example of a bordered edge below.

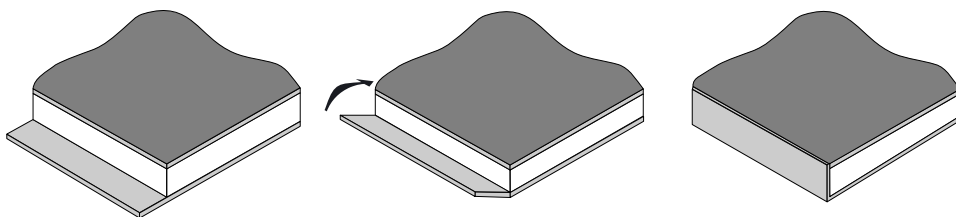

*cf. glossary

2. Bending*

a) General recommendations

The techniques used for bending* **SARAY®** are those generally used for working steel or aluminium sheet. However, the specific characteristics of the composite panel make certain precautions necessary.

Bending* techniques allow many different types of curved pieces to be formed, including fascias, parapets, airplane wing type profiles, cladding for posts and complex shapes (conical shapes).

When bending **SARAY®** the original protective film on the top surface must be left on. Depending on the conditions in the workshop, it is even advised that the protection be reinforced with another self-adhesive film or the insertion of polyethylene or PVC strips 1 to 2 mm thick. These essential precautions avoid marking and scratching that may only be discovered after installation, when the protective film is removed. Depending on the tools available and the type of application, one of the four following bending techniques will be used.

FABRICATION OF SARAY®

Fabrication

b) Bending* methods

| | Radius < 60 mm | Radius > 60 mm | Radius limited by diameter of rollers | Rotating part | Elliptical part |
|--|------------------|------------------|---------------------------------------|---------------|------------------|
| (A) Rollforming | | • | • | • | • ⁽¹⁾ |
| (B) Bending by press brake | | • | | | • |
| (C) Bending on an universal folding press with apron | | • | | | |
| (D) Bending after preliminary milling | • ⁽¹⁾ | • ⁽¹⁾ | | • | • |

⁽¹⁾ only if numerically controlled

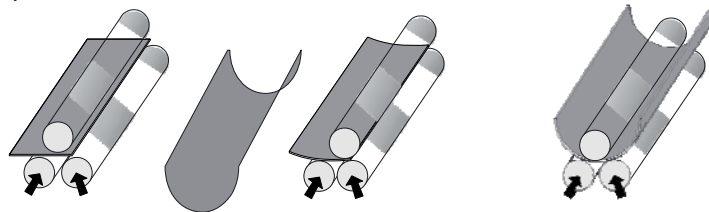

Before starting any work, see the chapter “Recommendations before use”, paragraph “Storage and handling of panels”, page 7.

(A) Rollforming

This operation consists of bending **SARAY®** panels in a conventional bender with three symmetrical polished cylinder rollers.

Caution when using:

- When carrying out the work, check that the rollers are not exerting too much pressure on the material.
- To obtain the radius required progressively, it may be necessary to put the panel through the machine several times.
- Test runs can be used to determine the number of times and the position of the cylinders.

- The multi-layered structure of the **SARAY®** panel causes a spring back effect that is more pronounced than that of steel or aluminium sheet.

- Feeding into and removal from the rollers may cause flattened sections at the ends of the panels. To eliminate this, it is a good idea to leave

60 to 80 mm extra length depending on the diameter of the rollers on either end of the panel, which can then be recut.

The use of a numerically controlled rollforming machine permits special fabrication operations such as the shaping of elliptical parts and also gives excellent repeatability.

*cf. glossary

ⓑ Bending by press brake

Press brakes can also be used to bend **SARAY**® panels by applying the techniques and experience gained from working with steel or aluminium sheet.

The bending operation is achieved by a die descending a given distance. The bending radius and angle depend on the diameter and travel of the upper punch as well as the width of the lower die. For this type of bending, the **SARAY**® panel will be protected by placing a flexible sheet with a hardness of at least 60 shores and thickness of 1.5 mm or more on either side of the panel. This protective layer ensures that the panel is displaced into the hollow of the lower die without marking it at the points of contact of the upper punch and lower die.

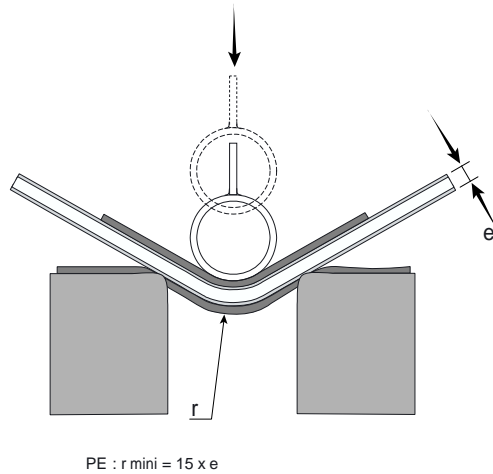

We recommend a minimum bending radius of 15 times the thickness of the panel.

FABRICATION OF SARAY®

Fabrication

ⓒ Bending with a folding press :

For this type of bending, the panel is held between two fixed beams on the folding bed. The folding apron bends the part of the panel sticking out around the upper beam of the folding tool. The bending radius depends on the radius of the interchangeable folding tools which are fixed on the upper sheet holder.

It is possible to obtain large bending radii using a stretching technique on a numerically controlled bending machine by combining the descent of the tool with the panel feed. In this case it is recommended that pads with protective shells be used to reduce the risk of facets forming. Extra protection must be used on the two outer surfaces of the **SARAY**® to avoid any marking occurring during the movements in the stretching process. In all cases, one or more test bends will need to be performed in order to find the optimum adjustment of the feed and the depth of the pad descent. Here account must be taken of a spring back phenomenon known to occur in aluminium-polyethylene composite panels.

ⓓ Bending after preliminary milling

Radii between 2 and 10 mm inclusive may be achieved by the rout and return technique. This consists of making V-shaped or straight grooves using shaped milling cutters on the reverse of the **SARAY**® composite panel. See paragraphs "Milling" and "Folding".

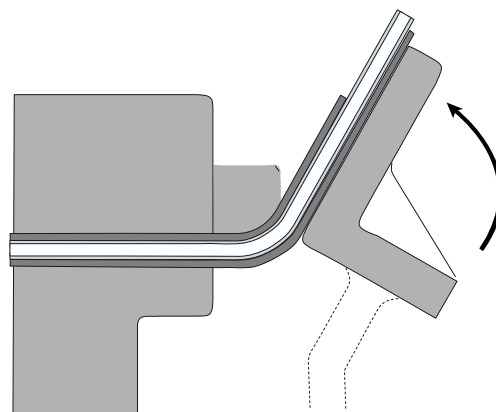

Intermediate radii of 10 to 60 mm can be achieved using a specific machining technique.

This technique, known as "paring", consists of removing a strip of the aluminium sheet on the back of the composite panel. The width of this strip will be equal to the flat size of the radius to be obtained. The depth must be determined by making prototypes to ensure that this operation does not affect the appearance of the front of the panel.

NB:

The use of this technique requires considerable experience of fabrication and excellent knowledge of the properties of the composite panel. In most cases, a reinforcement system will be required to compensate for the loss of rigidity of the bent part caused by this technique

General remark

:

Fully closed (360°) rotating parts can only be made by rollforming.

1. Riveting *

SARAY® panels can be assembled using the same rivets as aluminium.

The rivets are placed at least at 10 mm from the edge – and more where the **SARAY®** panels are used in a riveted façade system. The length of the rivets will depend on the thickness of the materials to be assembled. These values can be found in the supplier's technical data sheet.

Example of corner riveting for a cassette system

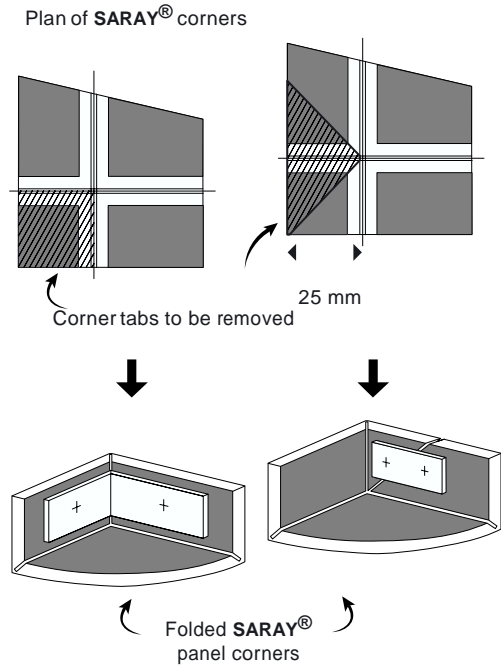

FABRICATION OF **SARAY®**

Assembly

The type of rivet used and its diameter will depend on the pressure exerted on the **SARAY®** panel. The right choice will avoid any risk of flying of the rivets.

For safety reasons, when choosing the rivets, we recommend that a factor of 3 be applied to the tensile strength and shear strengths given by the supplier. For outdoor use, allow at least 2 mm working clearance between the diameter of the rivet and the bore diameter of the hole in the **SARAY®** panel to allow for the linear expansion of 0.0236 mm/m/°C. It is essential that a step drill be used to achieve perfect coaxial drilling of the panel and the support.

See chapter "Recommendations before use", paragraph "Thermal expansion", page 7.

We advise that you follow the manufacturer's instructions in all cases and try some experimental riveting before starting production.

Painted rivets are particularly suitable for assemblies with visible rivets.

For the choice of accessories, please contact our

technical department.

Riveting without expansion

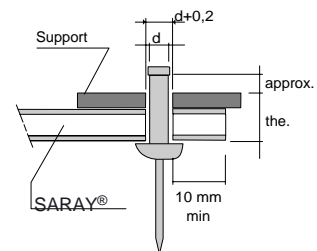

Riveting with expansion

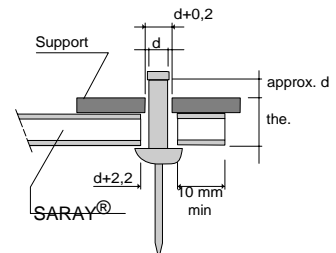

2. Screw fastening

The simplest method of assembly is threaded fasteners (bolts) with nuts. We recommend the use of large washers on both sides of the panel in order to distribute the tightening loads. Assembly without washers could cause creep and considerably reduce the tightening performance.

Assembly using traditional cladding screws is possible without any particular arrangements.

Assembly using countersunk head screws is performed after milling or simply by tightening the screw (countersinking).

Remark : assembly using threaded fasteners does not allow for the expansion of the panel and is therefore best suited for indoor use, and on an aluminium support (same coefficient of expansion as **SARAY**[®] panel).

FABRICATION OF SARAY[®]

Assembly

3. Continuous edge* grip

It is possible to assemble panels by continuous edge gripping using aluminium or synthetic profiles. For Sign & Display applications, the profiles used come in different shapes.

Depending on the shape of the profile, it may be possible, before assembling, to tighten the flanges of the profiles using a press. This improves the assembly's pullout strength. For outdoor or very large assemblies, we recommend extra fastening using rivets (which will be hidden underneath the gripping profile) so

as to avoid the panels coming apart.

*cf. glossary

4. Gluing

a) General recommendations

Gluing is a way of achieving invisible assemblies between **SARAY**[®] panels, but also on a wide range of substrates such as metals, plastics, composites or painted surfaces.

One and two-component adhesives, silicon mastic and double-sided adhesive tapes can all be used.

In all cases, the applications must be evaluated on a case by case basis by analysing the following criteria :

Surface condition :

Many surfaces that are difficult to glue (wood agglomerate board, plaster,...) can be treated with a primer to make them easier to glue.

Rough surfaces can be made smooth by abrasion.

On rough surfaces or to assemble two non-abutting parts, a thicker layer of adhesive will be necessary to compensate for the irregularities or fill the micro-pores (e.g. in wood) and provide a good contact between the adhesive and the two substrates.

To compensate for an uneven surface, double-sided adhesive tape may be used with a layer of foam of suitable thickness and flexibility.

Where problems of roughness and flatness occur together, we recommend the use of a visco-elastic foam tape.

Certain materials (copper, brass, plasticized PVC)

may require a primer or induction to avoid interaction between the adhesive and the substrate.

FABRICATION OF SARAY[®]

Assembly

Influence of surface energy on adhesion :

Adhesion is the result of the molecular attractive force between two different materials, comparable to a magnetic force (Van der Waals force). The attractive force is determined by the surface energy of the material as well as by the nature of the adhesive used. The higher the surface energy, the greater the molecular attraction and the wetting power of the adhesive. The assembly will therefore be stronger.

Mechanical stresses :

The mechanical stresses to which the assemblies are subjected fall into four main categories. Maximum mechanical strength will be obtained when the joint is subject to pull-off or shearing stresses ; peeling and splitting stresses should be avoided as far as possible.

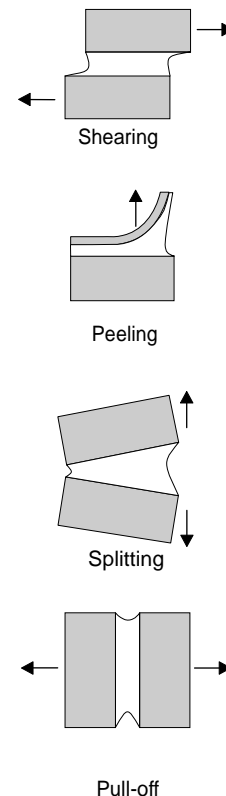

Environment:

Optimum application temperature : between 21 °C and 38 °C.

We do not recommend applications at temperatures below 10 °C. Special cases must be examined according to the product chosen.

Humidity : for good application, ensure that the surfaces are dry, and free of condensation.

Migration of plasticizers :

Plasticizers are added to PVC essentially in order to make the material more flexible. When an adhesive is applied to a surface, these plasticizers may migrate into the adhesive mass resulting in the softening of the adhesive which loses all cohesion. A product specially designed to resist plasticizers must therefore be selected.

FABRICATION OF SARAY®

Assembly

b) Methods

Surface preparation :

All adhesives and mastics require surface preparation for the best results. The aim is to eliminate from the surface all traces of paint, rust, oil or dust.

The importance of this preparation depends on the performances required of the glued joint and the operating cost.

As a rule, structural adhesives require thorough surface preparation if the performances promised are to be achieved. There are three techniques involved in preparing a surface :

- degreasing :

Cleaning with solvents is valid only for removing grease, oil etc. It is indispensable to use a hydro- carbonated solvent like heptane. If there is a resi- due of detergents and/or humidity, an alcohol- based solution such as isopropyl alcohol (IPA) or ethanol will be required.

Dry with a clean, non-fluffy cloth.

- abrasion :

The mechanical treatment of surfaces by abrasion (sandblasting, abrasive disks or strips or Scotch-brite™) gives excellent results for all materials that are thick enough not to be deformed. Cleaning will be necessary following the abrasion treatment.

- chemical treatment :

This is the best method for metal or glass surfaces. Each surface requires a particular chemical solution (acid or alkaline).

In all cases, we recommend that you refer to the manufacturer's instructions and carry out preliminary tests.

Double-sided adhesive tape may be used. The general recommendations for adhesives also apply. Firm application pressure (about 1 kg/cm²) increases adhesion and consequently holding power.

For this purpose, we advise use of a roller or scraper.

Invisible, removable fastening can be achieved by using Velcro® or Dual Lock™ - Scotchmate™ type fastening tape.

5. Hot air welding

a) General recommendations

This method is frequently used to assemble plastics and in particular SARAY® panels (on no account, does hot-air welding apply to panel assembly).

The filler rod and the polyethylene core are welded together after heating by a jet of hot air projected by an electrically heated welding gun.

For good quality welding, you need :

- good preparation of the edges to be welded together,
- adequate filler rod quality,
- a good welding speed,
- pressure evenly applied,
- clean hot air,
- an appropriate temperature.

b) Methods

Welding by the to-and-fro method :

Hold the filler rod at a right angle whilst exerting regular pressure on the rod, make to-and-fro B-B (non-circular) movements.

The filler rod and the edges to be welded must be heated in a similar way.

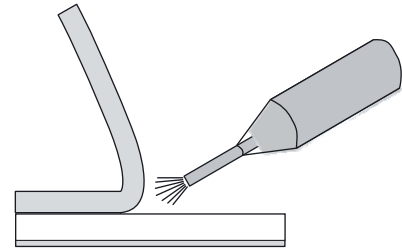

FABRICATION OF SARAY®

Assembly

Welding using a high-speed nozzle :

Principle : Normal hot air guns fitted with a removable high-speed welding nozzle allow the edges to be welded and the filler rod to be heated at the same time. This makes for better quality welding. The filler rod is pushed by the constant pressure of the high-speed nozzle, and is therefore pressed between the edges to be welded.

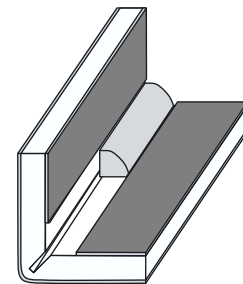
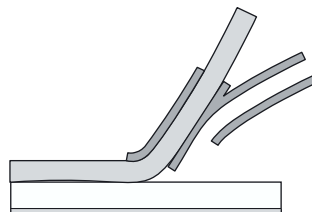
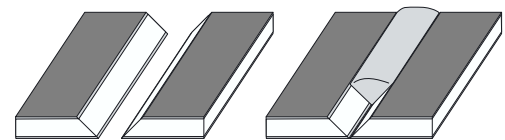

Figure A

General method statement :

Preparation of the edges to be welded :

- Butt welding : the edges must be bevelled, Figures B.
- Corner assembly : only one of the panels is bevelled.
- T-assembly : remove the narrow strip of metal skin to free the areas to be welded.
- Welding of a fold : bevel the edges to be welded first of all using a shaped milling cutter.



Figures B

Remark : remember that welding can under no circumstances be applied to panel assembly.

*cf. glossary

Practical advice :

The polyethylene core oxidizes relatively quickly once exposed to the air. It must be welded at the most 24 hours after it is bevelled. After it has cooled, it is possible to remove the welding flash using a knife or scraper. We recommend that this operation be carried out in a clean, oil and water-free area.

Use :

The specific welding qualities of the filler rod are:
Polyethylene low density
Colour unpigmented
Density 0.9 g/cm³
Ø of rod 3, 4 and 5 mm
Immediately before welding, remove the outer layer of oxide from the filler rod.

| Compressor pressure | Temperature | Bearing pressure | Welding speed |
|--------------------------|-------------|------------------|-------------------|
| To-and-fro method | 70l/min | 330 ±°5C | 3 kp 20-30 cm/min |
| High-speed nozzle method | 70l/min | 330 ±°5C | 3 kp 50-80 cm/min |

FABRICATION OF SARAY®

Assembly

6. Panel reinforcement

SARAY® panels can be stiffened by various means to resist wind loads and reduce panel deflection. Stiffeners are generally aluminium extrusions whose dimensions vary according to the inertia required. Adhered to the non-exposed back side of the panel at regular intervals, these stiffeners act like miniature beams. The wind load on the panel is transferred to the stiffeners, which act as true support beams and guide the thrust energy outwards towards the panel edge.

The fastenings used to attach the panel to the structural supports must be placed at or close to the stiffener end locations. Thus the loads are transferred from the panel to the stiffeners, then to the supports, in the most direct manner possible.

Stiffener spacing is a design decision that involves a number of variables such as stiffener strength, stiffener span, design wind load, allowable specified deflection (namely 1/30th of the width of the panel), panel thickness, fastener strength and support spacing. Because the maximum panel deflection is at the geometric centre of the panel, a stiffener should be placed there with the remaining stiffeners extending laterally at equal spacing from that point.

For more information on stiffener spacing and design loads, we advise you to contact our technical department which can carry out static calculations.

1. Post-painting*

a) General recommendations

Different qualities of coating can be post-painted. However, we do not recommend post-painting of PVDF* 70/30 resins.

Different results are obtained with different colours or resins, even from the same manufacturer.

Acrylic or two-component polyurethane air dry paints have been successfully tested. In some cases the drying process can be shortened by oven drying at a maximum of 70 °C.

Depending on the properties of the resins used in post-painting*, sometimes whitening can be seen in the folded areas. We advise that the elements be fabricated before post painting.

The polyethylene core of **SARAY®** panels suffers from prolonged contact with organic

solvents. The same applies to paints.

It is therefore recommended that some pre-testing be carried out and that the paint manufacturers' instructions are followed.

b) General method statement

1. Sand the surface with car body type glass paper using an eccentric sander.
2. Clean the surface with a blow gun or solvent.
3. Post-paint.

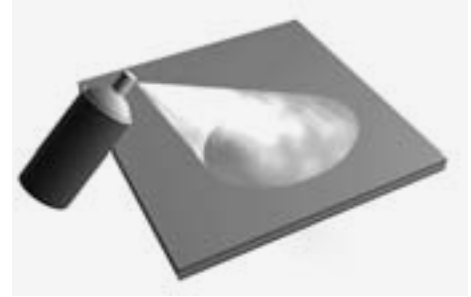

FABRICATION OF SARAY®

Surface treatment

2. Screen printing*

a) General recommendations

A clear protective coating is recommended for permanent outdoor exposure.

Painting:

(1) Caution

Pre-testing is recommended to check ink or paint compatibility with the SARAY® panel coating before large-scale painting is undertaken. Respect the manufacturer's instructions.

b) Screen printing* recommends on Polyester coating

| Supplier | Ink reference | 1 component | 2 components |
|---|---|----------------------------|--------------|
| TIFLEX S.A. B.P. 3, F- 01 450 Poncin | Urethal Polycolor | • | • |
| COATES SCREEN Mainstrasse 99 D- 90 451 Nürnberg | Z/PVC PO HG CX J CP | • • • • • | • • |
| PRÖLL Trechtlinger Strasse 29 D - 91 781 Weissenburg i. Bay | Thermo-Jet® PUR®-ZK Noristar® PG NoriPlan Norilit® NK N Sorte P Aqua-Jet® KSF | • • • • • • | • • |
| MARABU GmbH & Co. Postfach 152 D-71730 Tamm | Marastar SR Marasoft MS Ultraplus UVP | • • | • • |
| SERICOL GmbH Adolfheim St. 11 D-74321 Bissingen | Colorstar CS Mattplast MG Polyplast PY | • • | • |

3. Application of adhesives

a) General recommendations

Before application, ensure that the fabricated panels do not have any dents in the surfaces to be treated and that they are free of dust and grease. Self-adhesive plastic films and photographs coated beforehand with a suitable adhesive can be

applied without difficulty.

The ambient temperature and that of the support must correspond to that specified by the manufacturer for each type of film.

It should be noted that the minimum application temperature is about 4 °C.

FABRICATION OF SARAY®

Surface treatment

b) Method of applying the film to the support

Various methods may be employed depending on the size and shape of the decoration to be applied.

The general rules given below must be respected in all cases :

- Remove the strippable protective film at a 180° angle.
- Apply the adhesive with a scraper starting from the centre and moving out to the edges.
- Remove the top protection.

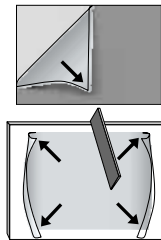

c) Particular precautions after removal of the protective paper

Rivet heads :

Around rivet heads, use a pin or a similar object (not knives or razor blades) to free any trapped air.

Overlapping metallic joining elements :

For a support joining element, use a razor blade as shown in the drawing below.

Air bubbles :

The last step consists of removing any air bubbles by pricking the edge of the bubble with a needle and pushing the air out with your thumb or a scraper.

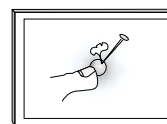
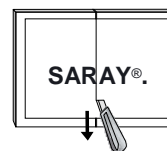
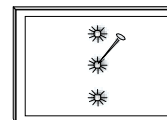

1. Cleaning

Regular cleaning is strongly recommended. Frequency of cleaning and the choice of the appropriate product will depend on the geographic location of the building and degree of soiling. Washing must be done in steps from the bottom upwards according to the following rules:

- manual cleaning or using special machines (industrial cleaner, foam machine etc.).

Ensure that pressure is moderate.

- use of appropriate detergents
- after cleaning, systematic and thorough rinsing of the surfaces with clean water to remove the remains of the detergent.

NB:

The excess rinsing water must be wiped with a sponge, rubber squeegee or chamois leather, to avoid streaking.

Precautions:

Never use products that dissolve the paint, namely:

- high alkaline products such as potash or caustic soda,
- acid products,
- abrasive scouring agents,
- solvents.

FABRICATION OF SARAY®

Maintenance

2. Coating touch-ups

We recommend that a full-size sample be test-painted before large-scale painting is undertaken. Panels may occasionally be scratched during fabrication and installation. Small scratches can be easily repaired with matching air dry paint using an artist's brush. Small dents may be repaired with automotive type body filler before being post-painted.

As stated previously, proper surface preparation, such as sanding and the application of a primer may

be required to achieve satisfactory results. - see chapter "Surface treatment", paragraph "Post-painting", page 28.

Pots of touch-up paint in the architectural range of colours are available on request.

For more details, see the paint manufacturer's application instructions.

*cf. glossary

For applications concerning **SARAY®**, Alcoa Architectural Products Merxheim is at your disposal to provide further information on the following subjects:

1. Projects

a) *Specification service*

During the preliminary study and design stages of projects,

- our sales department provides answers to questions relating to budgetary issues,
- our technical department will advise you about choice of products, technical installation solutions, panel dimensional restrictions, and will deal with special points.

b) *Optimisation service*

Panel production, optimisation of shapes according to the restrictions imposed by our production methods.

2. Processing

a) *Fabrication*

A list of experienced qualified fabricators is available. On request, extra documents can be sent to you presenting fabrication techniques and panel assembly methods.

b) *Machines*

Alcoa Architectural Products Merxheim can provide you with the details of specific machines and tools.

c) *Training*

Alcoa Architectural Products Merxheim has an on-site demonstration workshop where a trainer presents the different fabrication techniques as well as the machines and tools indispensable for the processing of **SARAY®**.

FABRICATION OF SARAY®

Information and service

3. Installation

Fastening systems – extrusions and accessories :

In our technical documents we offer information and guidelines about fastening systems.

Some of these systems are certified for façade cladding applications (technical certificates) : please ask your usual contact for further information.

4. Other information

For all other types of information concerning the characteristics of the product and the colour ranges, please see the specific documents available on request.

Warning:

This brochure has been drawn up based on the latest information available at the time of publication. Given the changes, improvements and other factors affecting the product, Alcoa reserves the right to modify or withdraw certain details without notice. The fitness for the purpose and method of use mentioned in this brochure, or any infringement of patent, are the sole responsibility of the user.

All the diagrams and information contained in this brochure are quoted for illustrative purposes only.

bending

Cylindrical shaping of a product by passing it through a suitably arranged set of rollers (rollforming machine). Bending may be achieved by several different processes, such as the press brake, the rollforming machine, the rolling- crushing...

blow gun

Device fitted on a flexible hose connected to a compressed air pipe, allowing pressurised air to be used to clean surfaces and cavities full of waste and dust.

boring

very precise machining of the inner surface of a rotating part, to bring the latter to the design dimension.

drilling

Operation consisting of making, in solid material, a cylindrical hole using a drill bit.

FABRICATION OF SARAY®

Glossary

edge

edge of the panel.

abutted edge :

assembly of two panels machined so that their joining together does not leave the edges visible. These two operations allow the two thicknesses of aluminium and the thickness of polyethylene to be masked.

bordered edge :

Folding over of a thickness of aluminium skin across the width of the panel.

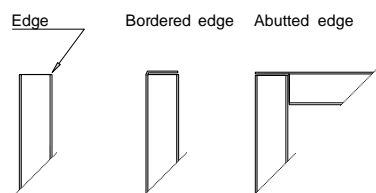
**fabrication**

Shaping operation by folding, stamping, bending...

groove flat

Refers to a flat portion or a rectangular section, not very thick.

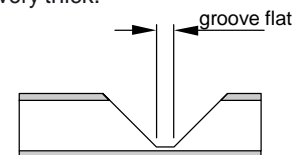
**groove cutting, routing**

Operation to cut grooves in a piece.

hot air welding

The welding operation consists of assembling two parts by causing them to melt at their edges, so as to obtain a regular, smooth and very strong join. PE is welded using a hot air source that melts it.

milling

Machining operation consisting of removing material using a rotating tool whose end contains sharp edges. The machine is a milling machine, the tool is a milling cutter.

PE

Abbreviation of "polyethylene"; used for the core of **SARAY**.

post-painting

Painting of products that have already undergone an intermediate treatment or shaping phase.

punching

Operation consisting of cutting the metal by means of two tools, one fitting onto the other : one is called the punch, the other the die.

PVDF

Abbreviation of "polyvinylidene chloride", a resin that makes up some of our paint coatings.

FABRICATION OF SARAY®

Glossary

riveting

Assembly of two or more metal parts brought together, drilled and with a rivet through them. The rivet is then clinched using a riveter.

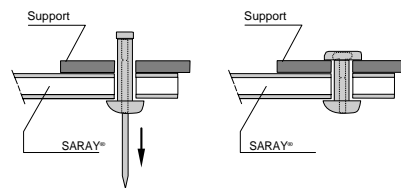
**screen printing**

Printing process which uses a screen made up of a mesh in which ink is applied through the unobstructed holes in the mesh that correspond to the picture to be printed.

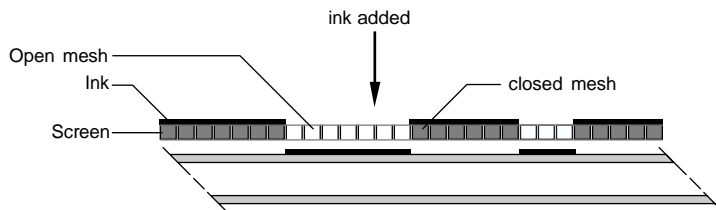
**squareness**

Squareness of the corners of panels or parts of a frame.

trimming : Operation consisting of removing the burrs that form during machining.